

SPECYFIKACJA TECHNICZNA

NOŻYCO-ROZPIERACZ FRONTLINER FX4-Fj

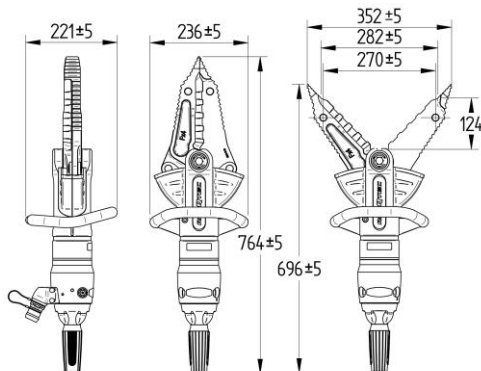

FRONTLINER FX4-Fj



Ciśnienie nominalne	Zoptymalizowane 350 bar	Zoptymalizowane 350 bar
Współczynnik bezpieczeństwa węża	-	8:1 (2,800 bar)
Wymiary (dł. x szer. x wys.)	764 x 236 x 221 mm	764 x 236 x 221 mm
Waga operacyjna	11.4 kg (±0.2kg)	12.6 kg (±0.2kg)
Max. otwarcie przy cięciu	282 mm	282 mm
Zasięg	124 mm	124 mm
Max. siła cięcia ¹	809 kN / 82.5 ton	809 kN / 82.5 ton
Zdolność cięcia wg. EN 13204	1I 2H 3I 4J 5I (klasa H)	1I 2H 3I 4J 5I (klasa H)
Zdolność cięcia wg. NFPA 1936	A6 B7 C6 D7 E6	A6 B7 C6 D7 E6
Pręt okrągły (S235 wg. EN 13204)	36 mm	36 mm
Max. otwarcie przy rozpięciu	352 mm	352 mm
Siła rozpięcia u podstaw ramienia (ostatni ząb) ¹	103 - 1080 kN / 10.5 - 108.4 ton	103 - 1080 kN / 10.5 - 108.4 ton
Siła rozpięcia 25 mm od końcówek	36.3 - 41.0 kN / 3.7 - 4.2 ton	36.3 - 41.0 kN / 3.7 - 4.2 ton
NFPA HSF	36.1 kN – 3.7 ton	36.1 kN – 3.7 ton
NFPA LSF	32.1 kN – 3.3 ton	32.1 kN – 3.3 ton
Max. otwarcie przy ciągnięciu	270 mm	270 mm
Siła pchania (w otworach)	59.4 - 70.7 kN / 6.0 - 7.2 ton	59.4 - 70.7 kN / 6.0 - 7.2 ton
Siła zgniatania 25mm od końcówek	43.3 - 48.7 kN / 4.4 - 5.0 ton	43.3 - 48.7 kN / 4.4 - 5.0 ton
NFPA HPF	43.9 kN – 4.5 ton	43.9 kN – 4.5 ton
NFPA LPF	39.0 kN – 4.0 ton	39.0 kN – 4.0 ton
EN 13204	CK36.3-352H-11.4	CK36.3-352H-12.6

AKCESORIA

Art. Nr.

AKCESORIA

Art. Nr.

światło LED USB

9500.1010

Mata 3x2m

9330.0777

zestaw łańcuchów & szekli FX4-Fj

2305.5100

Mata 2x1.5m

9330.0778

¹Maximum is a theoretical force that cannot be measured.

All forces with EN13204 certified power pack with pressure relief valves set conform EN13204 allowable pressure requirements



Information contained in this document is believed to be accurate. However RESQTEC does not guarantee the completeness or accuracy of any of the published information.

RESQTEC Zumro B.V.

Meer en Duin 82 | 2163 HC Lisse, the Netherlands

T +31 (0)252 419002

E info@resqtec.com

F +31 (0)252 411794

W www.resqtec.com

RESQTEC





KLASYFIKACJA WYDAJNOŚCI CIĘCIA WG EN13204 TABLICA 3 DLA NOŻYC I NARZĘDZI KOMBI

DU014K00





Producent	RESQTEC
Nazwa i typ urządzenia	Fx4-Fj HYD FRONTLINER COMBI-TOOL

KLASYFIKACJA:

TYP / OZNACZENIE / KLASYFIKACJA	MINIMALNA SIŁA ROZPIERANIA W kN	NOMINALNY DYSTANS OTWARCIA NOŻYC LUB ROZPIERANIA URZĄDZENIA KOMBI	MINIMALNA WYDAJNOŚĆ CIĘCIA	MASA W Kg (z dokładnością dziesiętną)	WYDAJNOŚĆ CIĘCIA
CK	36.3	352	H	11.4	1I-2H-3I-4J-5I

TYP PROFILU →	1 Pręt okrągły	2 Pręt płaski	3 Rura okrągła	4 Rura kwadratowa	5 Rura prostokątna
KATEGORIA ↓					
A	≥ 14	30 x 5	21,3 x 2,3		
B	≥ 16	40 x 5	26,4 x 2,3		
C	≥ 18	50 x 5	33,7 x 2,6	35 x 3	
D	≥ 20	60 x 5	42,6 x 2,6	40 x 4	50 x 25 x 2,5
E	≥ 22	80 x 8	48,3 x 2,9	45 x 4	50 x 30 x 3,0
F	≥ 24	80 x 10	60,3 x 2,9	50 x 4	60 x 40 x 3,0
G	≥ 26	100 x 10	76,1 x 3,2	55 x 4	80 x 40 x 3,0
H	≥ 28	110 x 10	76,1 x 4,0	60 x 4	80 x 40 x 4,0
I	≥ 32	120 x 10	88,9 x 4,0	60 x 5	80 x 40 x 5,0
J	≥ 36	130 x 10	88,9 x 5,0	70 x 4	100 x 50 x 4,0
K	≥ 40	140 x 10	101,6 x 4,0	70 x 5	100 x 50 x 5,0

WYDAJNOŚĆ CIĘCIA WG NFPA 1936 DLA NOŻYC I NARZĘDZI KOMBI

										A6 B7 C6 D7 E6	
TYP PROFILU →	A Pręt okrągły		B Pręt płaski		C Rura okrągła		D Rura kwadratowa		E Kątownik		
POZIOM											
WYDAJNOŚCI											
↓	inch	mm	inch	mm	inch	mm	inch	mm	inch	mm	
1	3/8	9.5	1/4 x 1/2	6.4 x 13,7	3/8 0.68 x 0.09	17.2 x 2.2	1/2 x 0.06	12.7 x 1.5	1/2 x 1/8	12.7 x 3.17	
2	1/2	12.7	1/4 x 1	6.4 x 25.4	3/4 1.05 x 0.11	26.6 x 2.79	1 3/4 x 0.06	19.1 x 1.5	1 x 1/8	25.4 x 3.17	
3	5/8	15.8	1/4 x 2	6.4 x 50.8	1 1.32 x 0.13	33.5 x 3.3	1 x 0.08	25.4 x 2	1 1/4 x 3/16	31.7 x 4.8	
4	3/4	19.1	1/4 x 3	6.4 x 76.2	1 1/4 1.66 x 0.14	42.2 x 3.2	1 1/4 x 0.12	31.7 x 3	1 1/2 x 3/16	38.1 x 4.8	
5	7/8	22.2	1/4 x 4	6.4 x 101.6	1 1/2 1.90 x 0.15	48.3 x 3.2	1 1/2 x 0.12	38.1 x 3	1 1/2 x 1/4	38.1 x 6.35	
6	1	25.4	3/8 x 3	9.5 x 76.2	2 2.38 x 0.15	60.5 x 3.8	1 3/4 x 0.12	44.5 x 3	1 3/4 x 1/4	44.5 x 6.35	
7	1 1/4	31.8	3/8 x 4	9.5 x 101.6	2 1/2 2.88 x 0.20	73.2 x 5.1	2 x 0.15	50.8 x 3.8	1 1/2 x 3/8	38.1 x 9.5	
8	1 1/2	38.1	3/8 x 5	9.5 x 126	3 3.50 x 0.22	88.9 x 5.6	2 1/2 x 0.19	63.5 x 4.6	2 x 3/8	50.8 x 9.5	
9	1 3/4	44.45	3/8 x 6	9.5 x 152.4	3 1/2 4.00 x 0.23	101.6 x 5.8	3 x 0.19	76.2 x 4.8	2 1/2 x 3/8	63.5 x 9.5	



ul. Reja 38, Suchy Dwór, 81-198 Gdynia
 tel./fax +48 58 781 78 55, tel. +48 58 665 79 93
info@safetech.net.pl, www.safetech.net.pl